

Woofers 15" especially designed for applications where the low weight is the important factor, as: portable speakers or suspended systems (Fly).

- Excellent low to midrange response that's optimal for small to medium sound reinforcement systems;
- Ideal for use in two-way sound reinforcement systems for auditoriums, houses of worship, and night clubs;
- A good, safer choice when the lower weight of the speakers are important considerations for portability or rigging issues;
- **Ultra High Efficiency (UHE)** Neodymium woofers have high output power to weight ratios. The efficient design has higher output for a given input power which reduces power compression and produces clear, low distortion sound;
- Powerful Rare Earth "Neo" magnets in our proprietary **Cast Flux Return (CFR)** structures were optimized through our special metallurgy processing and Finite Element Analysis to produce higher magnetic fields from dramatically lower weight materials when compared to both conventional ceramic & Neo magnet woofers;
- The **CFR** structure contains the magnetic flux (video shielded), wicks away the heat through multiple venting of the rear heat sink fins and weighs less so there is no need for an aluminum cast frame allowing us to use a cost effective epoxy coated steel frame;
- Copper wire coils on high temperature TIL formers reinforced with fiber glass for greater power handling and reliability;
- Specially treated, long fiber paper cones that are strong and light weight for increased efficiency;
- Proprietary surround featuring a combination half roll with an integrated accordion design produces an incredible flat midrange frequency response;
- Rubber infused cloth suspensions for increased durability and longer lifespan;
- High temperature structural adhesives for stronger component bonds.

*15W12P-Nd SLF: Product without Selenium logo printed on the dust cap.

SPECIFICATIONS

Nominal diameter	380 (15)	mm (in)
Nominal impedance	8	Ω
Minimum impedance @ 189 Hz	5.9	Ω
Power handling		
Musical Program ¹	400	W
AES ²	200	W
Sensitivity (2.83V@1m) averaged from 60 to 4,000 Hz	99	dB SPL
Power compression @ 0 dB (nom. power)	5.31	dB
Power compression @ -3 dB (nom. power)/2	3.10	dB
Power compression @ -10 dB (nom. power)/10	0.91	dB
Frequency response @ -10 dB	55 to 4,500	Hz

¹ Power handling specifications refer to normal speech and/or music program material, reproduced by an amplifier producing no more than 5% distortion. Power is calculated as true RMS voltage squared divided by the nominal impedance of the loudspeaker.

² AES Standard (60 - 600 Hz).

THIELE-SMALL PARAMETERS

Fs	38.5	Hz
Vas	222 (7.84)	l (ft ³)
Qts	0.67	
Qes	0.72	
Qms	9.37	
η ₀ (half space)	1.70	%
Sd	855.3 (133.6)	cm ² (in ²)
Vd (Sd x Xmax)	86.0 (5.25)	cm ³ (in ³)
Xmax (max. excursion (peak) with 10% distortion)	1.0 (0.4)	mm (in)
Xlim (max. excursion (peak) before physical damage)	18.0 (0.70)	mm (in)

Atmospheric conditions at TS parameter measurements:

Temperature	25 (77)	°C (°F)
Atmospheric pressure	1,016	mb
Humidity	51	%

ADDITIONAL PARAMETERS

βL	12.1	Tm
Flux density	1.1	T
Voice coil diameter	60 (2.36)	mm (in)
Voice coil winding length	14.0 (45.9)	m (ft)
Wire temperature coefficient of resistance (α ₂₅)	0.00357	1/°C
Maximum voice coil operating temperature	280 (536)	°C (°F)
θ _{vc} (max. voice coil operating temp./max. power)	1.4 (3.42)	°C/W (°F/W)
H _{vc} (voice coil winding depth)	10.0 (0.4)	mm (in)
H _{ag} (air gap height)	8.0 (0.32)	mm (in)
Re	5.61	Ω
Mms	79.4 (0.17)	g (lb)
Cms	220	μm/N
Rms	2.05	kg/s

NON-LINEAR PARAMETERS

Le @ Fs (voice coil inductance @ Fs)	1.37	mH
Le @ 1 kHz (voice coil inductance @ 1kHz)	0.814	mH
Le @ 20 kHz (voice coil inductance @ 20 kHz)	0.504	mH
Red @ Fs	0.084	Ω
Red @ 1 kHz	1.572	Ω
Red @ 20 kHz	23.305	Ω
K _{rm}	0.6	mΩ
K _{xm}	3.3	mH
E _{rm}	0.90	
E _{xm}	0.84	

Parameters are measured after a 2-hour power test using half AES power. A variation of ± 15% is allowed.



ADDITIONAL INFORMATION

Magnet material	Neodymium
Magnet weight	180 (6.35) g (oz)
Magnet diameter x depth	56 x 10 (2.2 x 0.4) mm (in)
Magnetic assembly weight	1,550 (3.42) g (lb)
Frame material	Steel
Frame finish	Black epoxy
Magnetic assembly steel finish	Zinc-plated
Voice coil material	Copper
Voice coil former material	TIL/Fiber
Cone material	Long fiber pulp
Volume displaced by woofer	6.0 (0.21) l (ft ³)
Net weight	2,400 (5.30) g (lb)
Gross weight	3,000 (6.61) g (lb)
Carton dimensions (W x D x H)	39.3 x 39.3 x 16.7 (15.5 x 15.5 x 6.6) cm (in)

MOUNTING INFORMATION

Number of bolt-holes	8
Bolt-hole diameter	5.5 x 8 (0.21 x 0.32) mm (in)
Bolt-circle diameter	367 (14.5) mm (in)
Baffle cutout diameter (front mount)	355 (13.97) mm (in)
Baffle cutout diameter (rear mount)	348 (13.70) mm (in)
Connectors	Push on terminals
Polarity	Positive voltage applied to the positive (+) terminal gives forward cone motion
Minimum clearance between the back of the magnetic assembly and the enclosure wall	75 (3) mm (in)

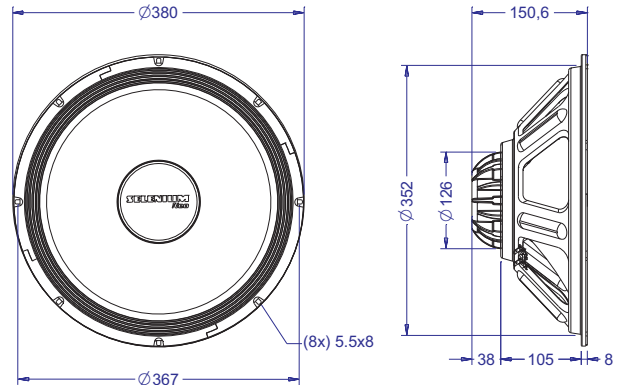

Dimensions in mm.

RESPONSE CURVES (0° AND 45°) IN A TEST ENCLOSURE INSIDE AN ANECHOIC CHAMBER, 1 W / 1 m

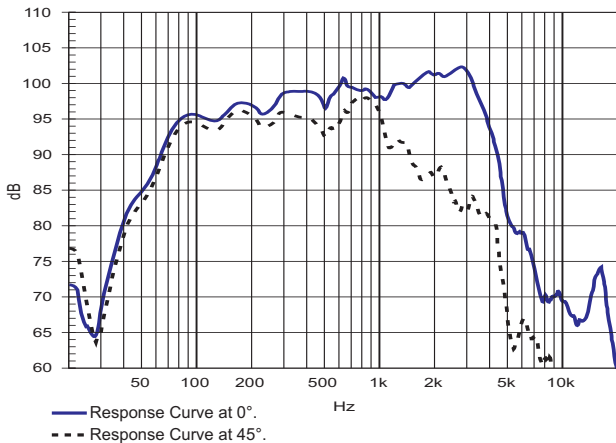

IMPEDANCE AND PHASE CURVES MEASURED IN FREE-AIR

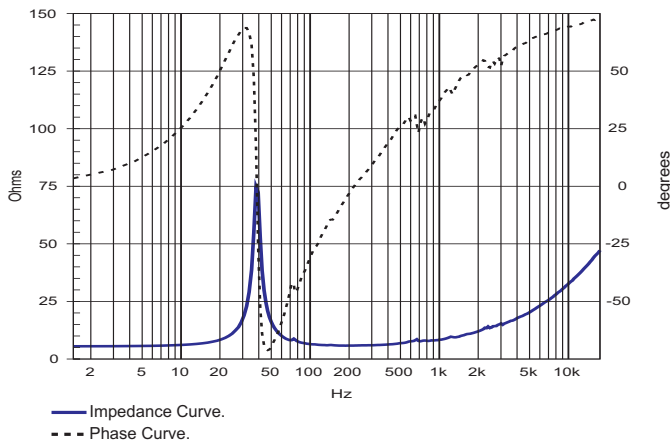

HARMONIC DISTORTION CURVES MEASURED AT 10% AES INPUT POWER, 1 m

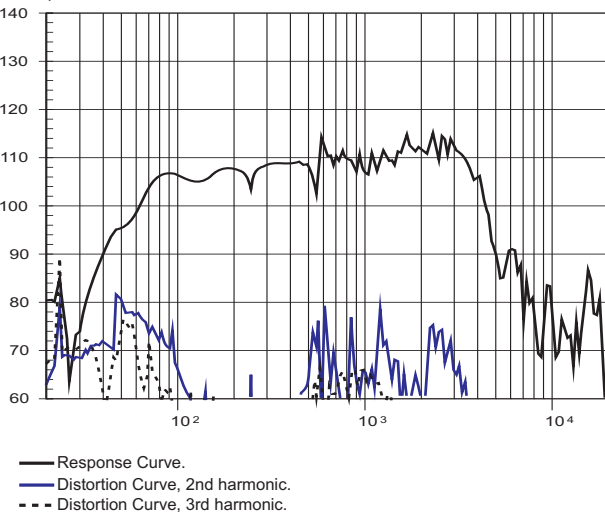

POLAR RESPONSE CURVES

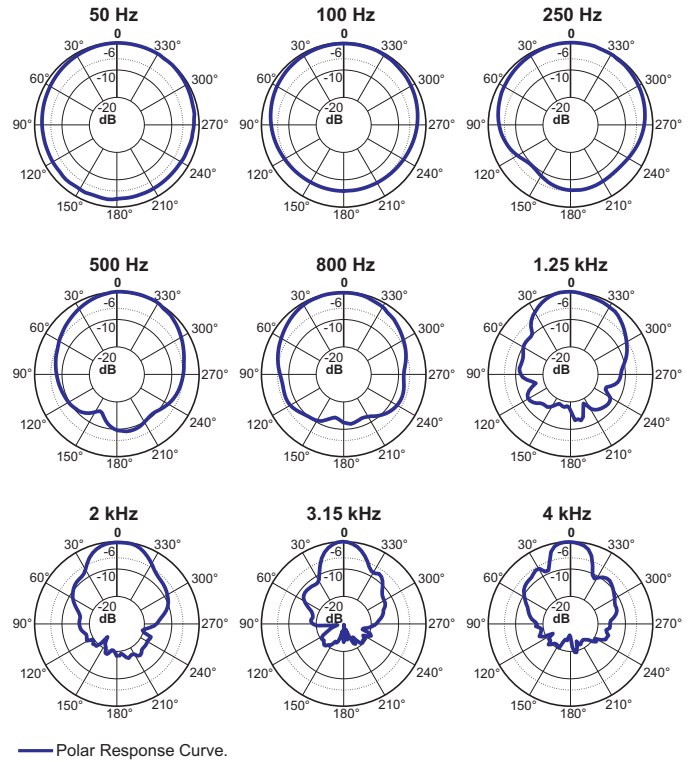

HOW TO CHOOSE THE RIGHT AMPLIFIER

The power amplifier must be able to supply twice the RMS driver power. This 3 dB headroom is necessary to handle the peaks that are common to musical programs. When the amplifier clips those peaks, high distortion arises and this may damage the transducer due to excessive heat. The use of compressors is a good practice to reduce music dynamics to safe levels.

FINDING VOICE COIL TEMPERATURE

It is very important to avoid maximum voice coil temperature. Since moving coil resistance (R_e) varies with temperature according to a well known law, we can calculate the temperature inside the voice coil by measuring the voice coil DC resistance:

$$T_B = T_A + \left(\frac{R_B}{R_A} - 1 \right) \left(T_A - 25 + \frac{1}{\alpha_{25}} \right)$$

T_A, T_B = voice coil temperatures in °C.

R_A, R_B = voice coil resistances at temperatures T_A and T_B , respectively.

α_{25} = voice coil wire temperature coefficient at 25 °C.

POWER COMPRESSION

Voice coil resistance rises with temperature, which leads to efficiency reduction. Therefore, if after doubling the applied electric power to the driver we get a 2 dB rise in SPL instead of the expected 3 dB, we can say that power compression equals 1 dB. An efficient cooling system to dissipate voice coil heat is very important to reduce power compression.

NON-LINEAR VOICE COIL PARAMETERS

Due to its close coupling with the magnetic assembly, the voice coil in electrodynamic loudspeakers is a very non-linear circuit. Using the non-linear modeling parameters $K_{rm}, K_{xm}, E_{rm}, E_{xm}$ from an empirical model, we can calculate voice coil impedance with good accuracy.

SUGGESTED PROJECTS

For additional project suggestions, please access our web site.

TEST ENCLOSURE

110-liter volume with a duct \varnothing 4" by 1,7" length.