



Features:

- 96dB sensitivity 1W/1m
- 200W Power handling
- Extremely light weight of 1.98kg
- 2" aluminium sandwich voice coil for low power compression
- Double treated cone for water protection
- Neodymium magnet system
- Triple aluminium demodulating rings for ultra low distortion
- Optimal for compact 2-way systems

SPECIFICATIONS

APPLICATION	Low-Middle	
Nominal impedance	Ohm	8
Power handling AES noise	W	200
Sensitivity (1W/1m)	dB	96
Frequency response	Hz	80 - 3000
Voive coil diameter	mm	52 (2")
Voice coil material		Al
Voice coil winding depth	mm	15
Magnet gap depth	mm	7
Basket		Cast Aluminium
Effect. diaphragm diameter D	mm	168

THIELE - SMALL PARAMETERS			
Resonance frequency	Fs	Hz	87.7
DC resistance	Re	Ohm	5.40
Mechanical Q factor	Qms		4.34
Electrical Q factor	Qes		0.32
Total Quality factor	Qts		0.30
Equivalent volume	Vas	L	11.04
Moving mass	Mms	kg	0.0206
Mechanical compl.	Cms	mm/N	0.16
BL factor	BL	Tesla m	13.80
Effective piston area	Sd	m ²	0.0222
Max. linear excursion	Xmax	mm	± 4
Voice coil inductance	Le1k	mH	0.20 (4 Ohm)
	Le10k	mH	0.12 (4 Ohm)

MOUNTING INFORMATION		
Overall diameter	mm	205
Mounting holes diameter	mm	4 x (6 x 6.5)
Bolt circle diameter	mm	195 - 197
Baffle cut-out diameter	mm	182
Overall depth	mm	102
Net weight	kg	1.98

Recommended reflex enclosure:

4L/108Hz, BRD=60mm/127mm long

7L/82Hz, BRD=60mm/126mm long

10L/70Hz, BRD=60mm/111mm long

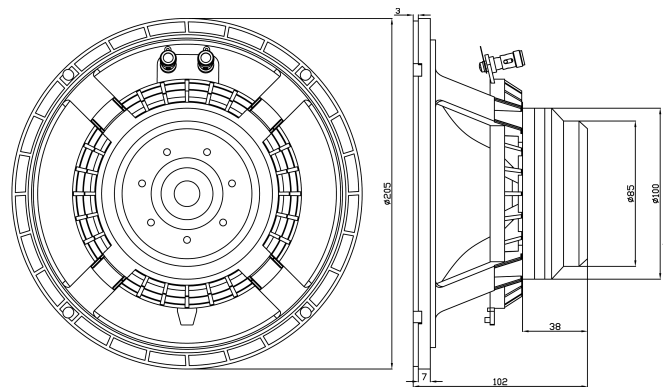

Frequency response measured 100W (28.3V) at 1m in a closed enclosure of 10 litre incl. 2nd and 3rd harmonic distortion raised 20dB.

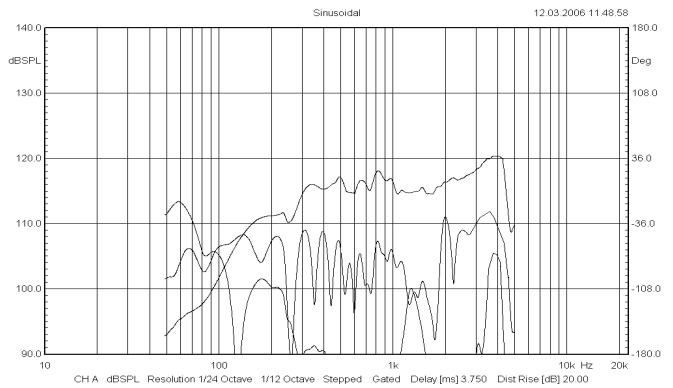

Impedance - 4 Ohm driver

