

C173-6-191E

Bass - midrange driver

DOMEMATERIAL: CERAMIC
APPLICATION: BASS - MIDRANGE
NOMINAL DIAMETER: 173 mm
SENSITIVITY: 88 dB

MAIN FEATURES :

SPECIAL DOME CUTOUTS

OVERHUNG MOTOR DESIGN

38 MM TITANIUM VC FORMER

HIGH SHAPE RUBBER SURROUND

VENTED VC, POLE PIECE & SPIDER

35 HZ - 2.8 KHZ IN VENTED BOX



The **C173 - 6 - 191E** is a 6.5 inch bass-midrange driver with ultra hard **ceramic dome**.

Anti - resonant **cutout fills** in the ceramic dome provide for damping of the 4 kHz dome resonance.

A **FEA optimized** overhung motor design with 38 mm titanium voice coil former guarantees very low energy storage and good heat transfer.

The high shape rubber surround and a **thin fabric spider** center the moving parts with high linearity.

As a typical home stereo bass - midrange driver, we recommend our C173-6-191E for an application from 35 Hz - 2800 Hz.

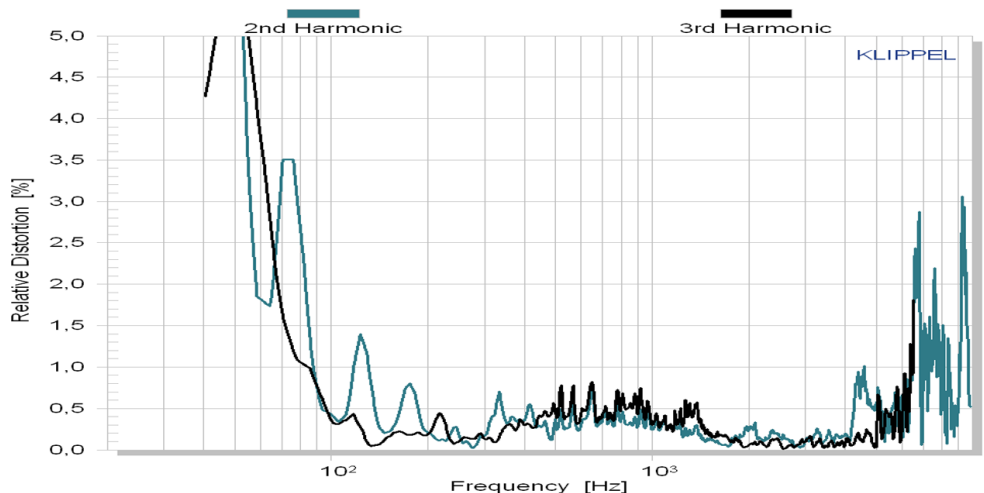
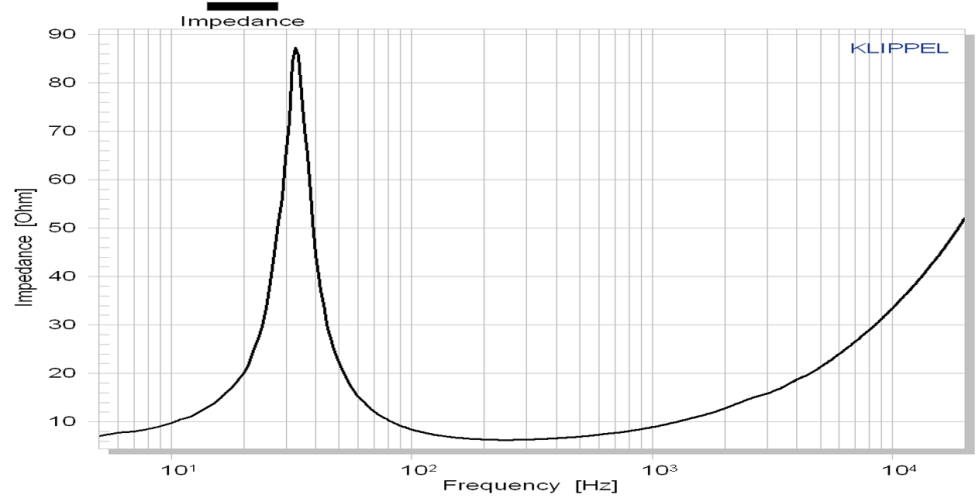
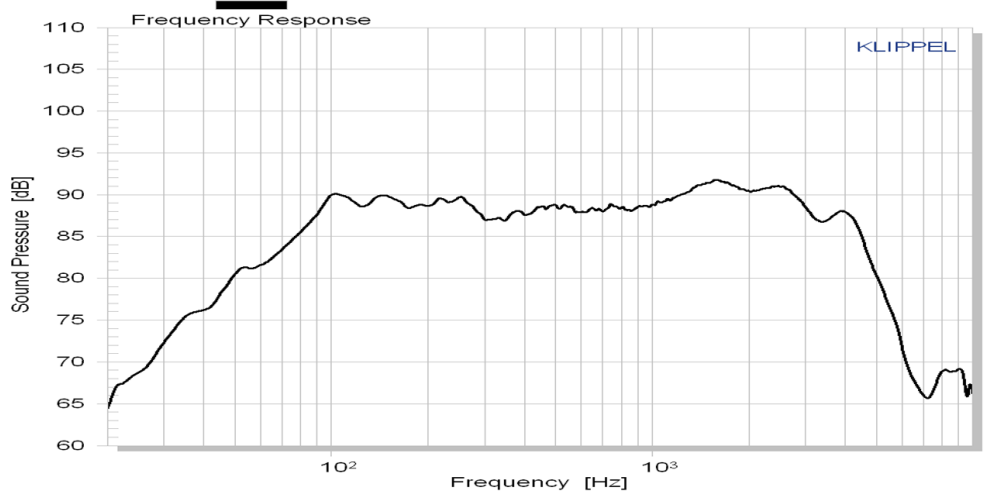



C173-6-191E
Bass-midrange driver

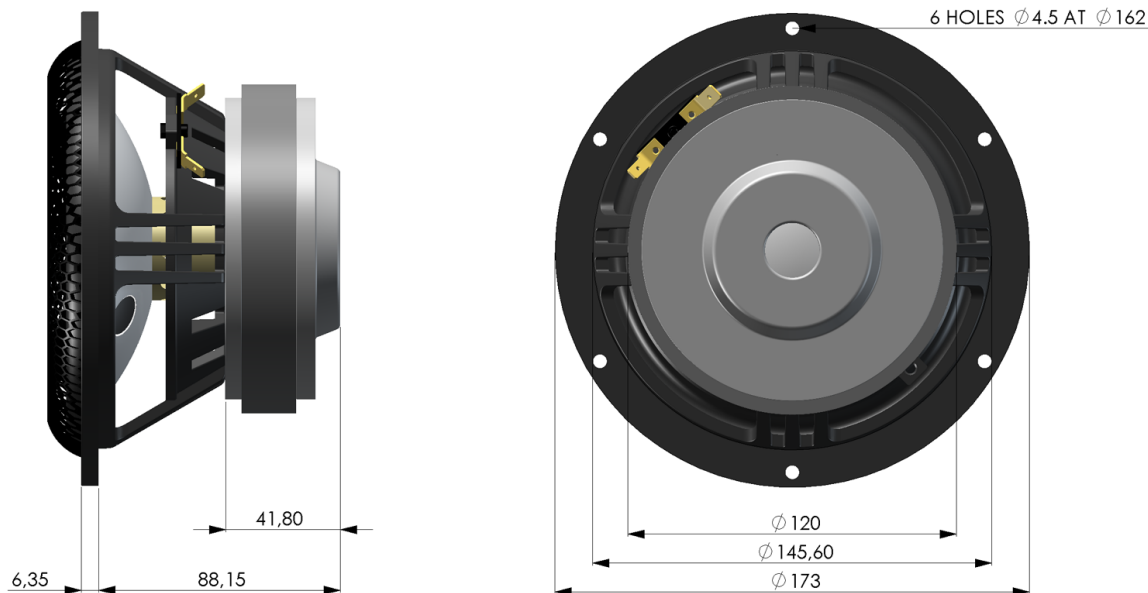

Mechanical data		
Overall diameter	173	mm
Cutout diameter	145.6	mm
Frontplate depth	6.35	mm
Overall depth	94.5	mm
Motor assembly diameter	120	mm
Motor assembly depth	41.8	mm
Screw fitting	DIN 7984, 4mm	
Terminal	+ : 6.3 x 0.8 / - : 4.8 x 0.8	mm
Shipping weight / net weight	2.6 / 2.28	kg
Shipping size	210 / 140 / 210	mm

Thiele/Small Parameters			
Sensitivity (2.83V / 1m)	Lp	88*	dB
DC-resistance	Re	5.8	Ohm
Resonance frequency	Fs	33	Hz
Equivalent volume of air	Vas	33	L
Mechanical Q	Qms	5.1	
Electrical Q	Qes	0.34	
Total Q	Qts	0.32	
Effective piston area	Sd	132	cm ²
Moving mass	Mms	19.2	g
Suspension compliance	Cms	1.2	mm/N
Mechanical resistance	Rms	0.75	kg x s

Voice Coil data			
Power handling	P	120*	Watt
Linear excursion	Xmax	+/- 5	mm
Voice coil diameter		38	mm
Voice coil former material		Ti	
Voice coil material		Cu	
Voice coil inductance	Le	0.7	mH
Force factor	Bl	8.5	N/A
Motor type		Overhung	
Ferrofluid filling		no	

* Please refer to www.accuton.com for exact measurement conditions and further information.

All rights reserved - All data with reservation and subject to change.

Thiel & Partner GmbH Kantstrasse 1 50259 Pulheim T +49 (0) 2238 / 475475 a.bankewitz@accuton.com